

8 Burner Stainless Steel Event Grill
ITM. / ART. 1031506
Model: 780-0838

Care & Assembly Instructions

IMPORTANT, RETAIN FOR FUTURE REFERENCE: READ CAREFULLY

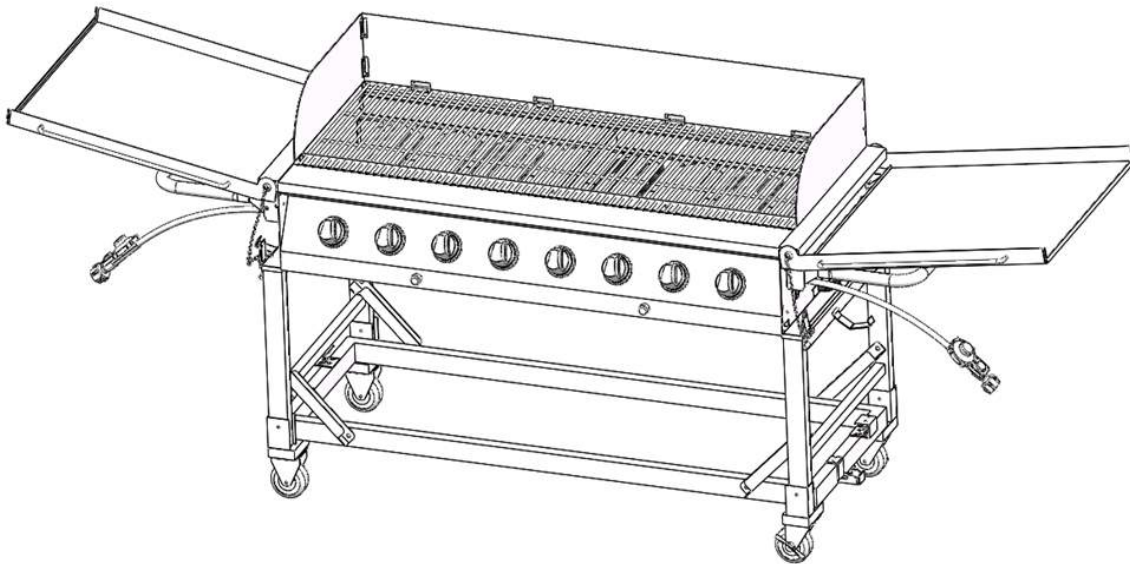

Warning:

- For outdoor use only.
- This instruction manual contains important information necessary for the proper assembly and safe use of the appliance.
- Do not leave the appliance unattended. Keep young children and pets away.
- Do not move the device during use.
- Not intended to be installed in or on boats and should never be used as a heater.
- Close the valve of the gas cylinder after use.

FOR YOUR SAFETY

Do not store or use gasoline or other flammable vapors and liquids in the vicinity of this or any other appliance.

▲ Warning : Improper installation, adjustment, alteration, service or maintenance can cause property damage, injury or death. Read the installation, operating and maintenance instructions thoroughly before installing or servicing this equipment.

Questions, problems, and/or missing parts? Before returning to your retailer, please send an email to our customer service department: nxracs@duro-global.com



**If you prefer to speak to a live agent; call 1-888-909-8818 (USA/CANADA)
Monday-Friday 9 AM-5 PM PST;
Languages Spoken: English, Spanish, French.**

EXPLODED VIEW

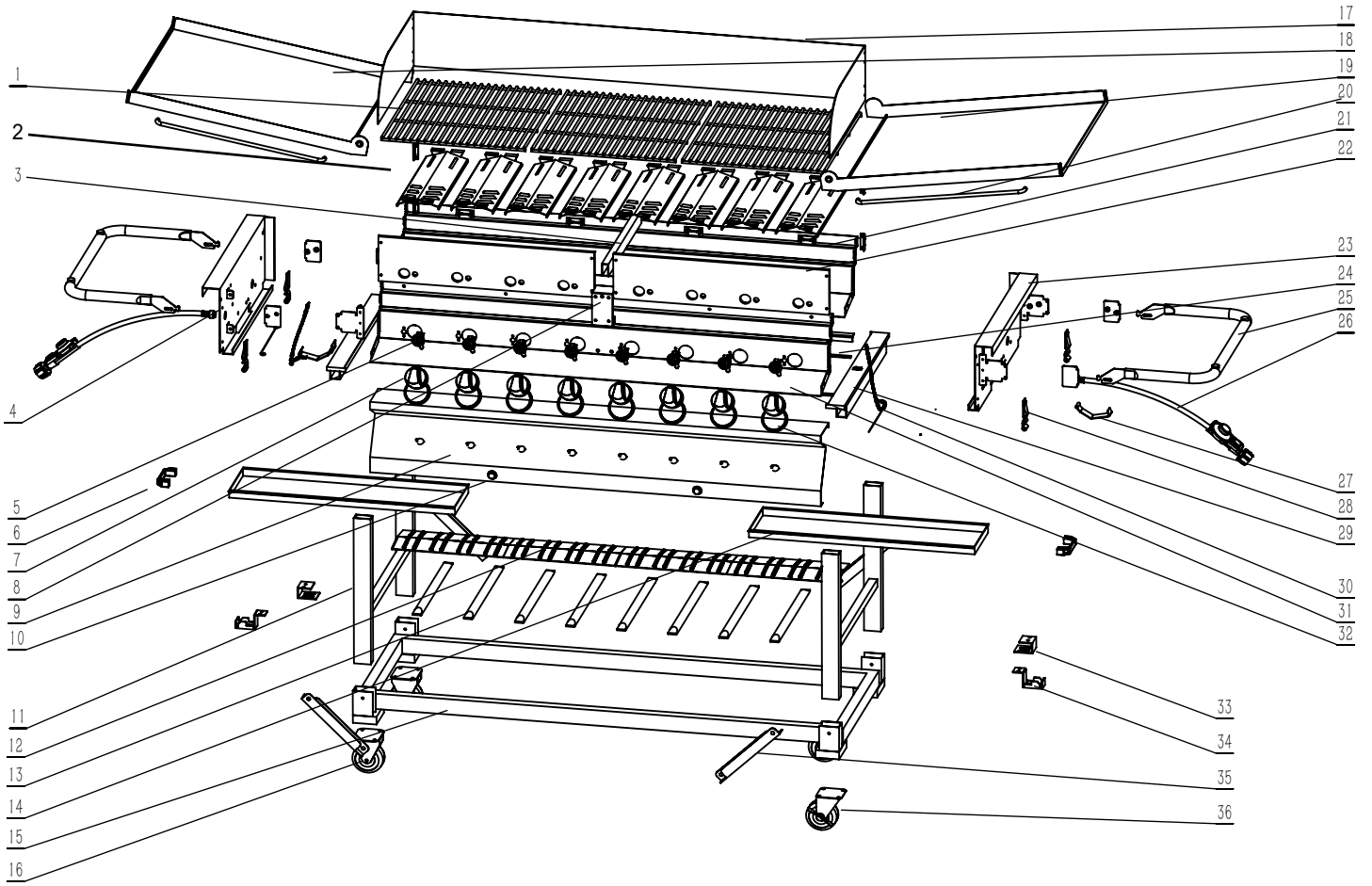

PARTS LIST

Part Number	Part Description	Qty
1	cooking grid	4pcs
2	flame tamer	8pcs
3	fire box division plate	1pc
4	fire box left side panel	1pc
5	gas valve	8pcs
6	grease tray handle	2pc
7	control knob	8pcs
8	flame tamer support	1pc
9	control panel	1pc
10	pulse ignitor	2pcs
11	left leg assembly	1pc
12	fire box bottom panel	1pc
13	main tube burner	8pcs
14	grease tray	2pcs
15	cart bottom frame	1pc
16	fixed caster	2pcs
17	wind shield assembly	1pc
18	main lid left	1pc
19	main lid,right	1pc
20	main lid, handle	2pcs

Part Number	Part Description	Qty
21	fire box rear panel	1pc
22	fire box front panel	1pc
23	fire box right side panel	1pc
24	mainfold	1pc
25	side handle	2pcs
26	regulator	2pcs
27	gas tank hook	2pcs
28	latch lock	4pcs
29	upside beam	2pcs
30	lighting rod	2pcs
31	fire box heat insulation plate	1pc
32	control knob bezel	8pcs
33	cart bottom frame hanger	2pcs
34	gas tank holder	2pcs
35	cart leg slide support	4pcs
36	swivel caster	2pcs

PACKAGE CONTENT LIST

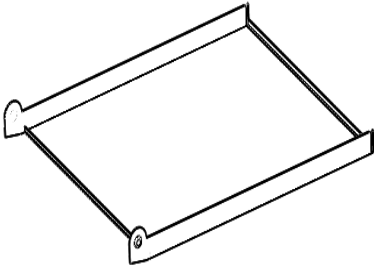
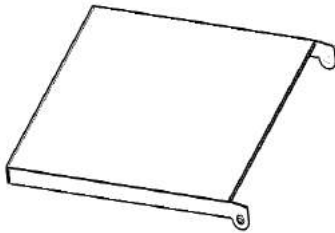
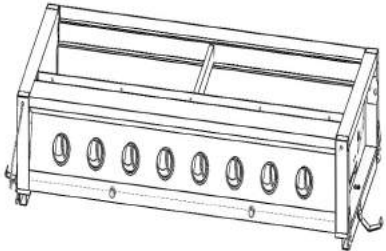
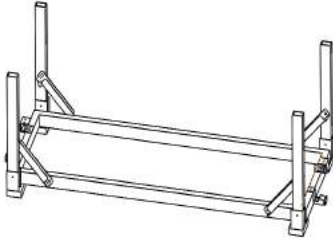
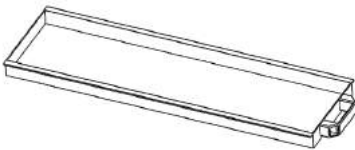
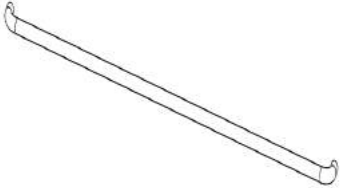
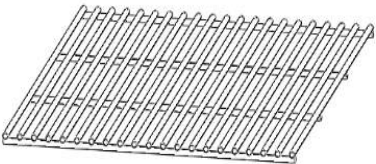
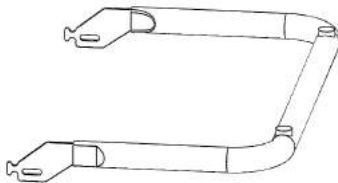
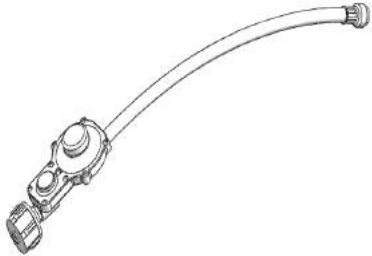
Main Lid,left:1pc 	Main Lid,right:1pc 	Fire Box Assembly:1pc 
Cart Assembly:1pc 	Grease Tray:2pcs 	Main Lid Handle:2pcs 
Cooking Grid:4pcs 	Cart Handle:2pcs 	Hose and Regulator:2pcs 

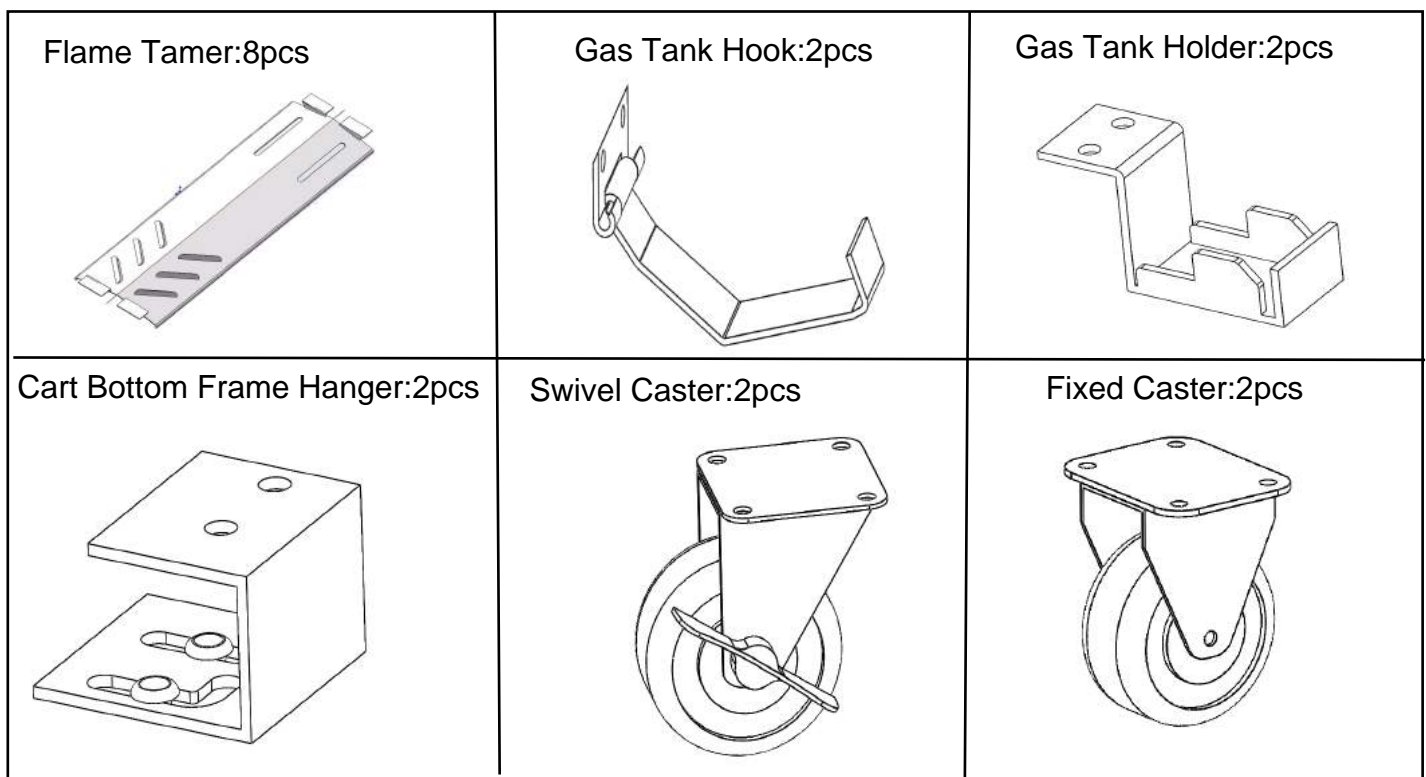

HARDWARE CONTENTS

Pack	Description	Required for assembly	Extra hardware	Total
AA	1/4 x 12-mm Truss Head Screw	20 pcs.	2 pcs.	22 pcs.
BB	1/4 Locking Washer	16 pcs.	2 pcs.	18 pcs.
CC	1/4 Flat Washer	16 pcs.	2 pcs.	18 pcs.
DD	1/4x17.5mm Truss Head Screw	8 pcs.	2 pcs.	10 pcs.
EE	5/32x10mm Truss Head Screw	4 pcs.	1pcs	5 pcs.

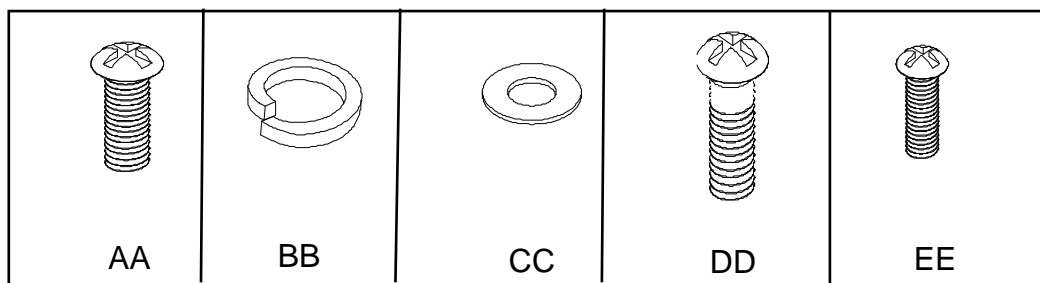

ASSEMBLY INSTRUCTIONS

1. Install Casters

NOTE: We recommend at least 2 people to assemble grill.

- Lift the Cart out of shipping carton and place it on the cardboard work surface.
- Install the Casters to the cart leg with Screw #AA, make sure the 2 swivel casters on the right side.

Warning: Make sure that all casters have been tightened before unfold the legs of cart.

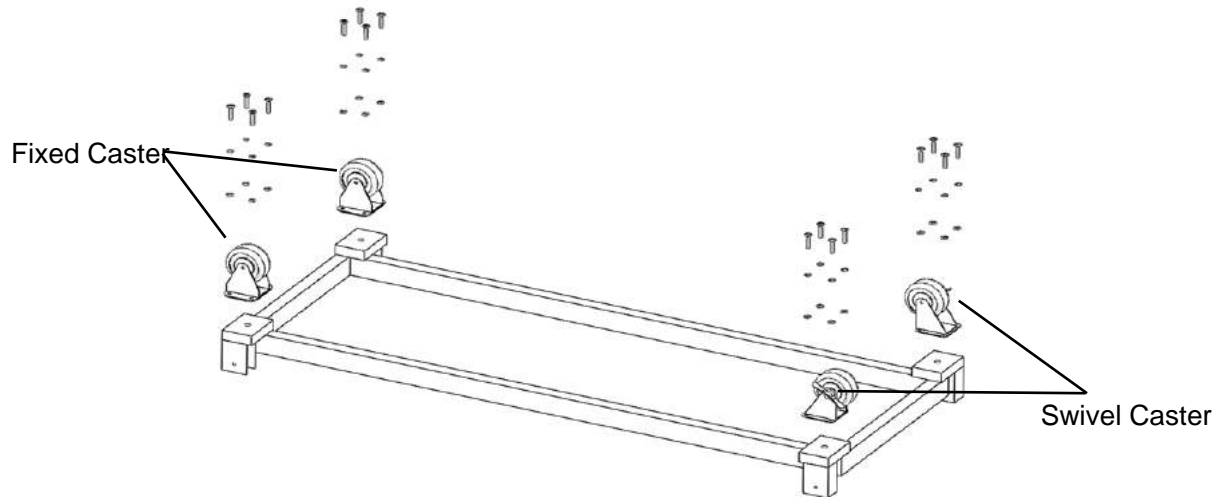

AA:16pcs
BB:16pcs
CC:16pcs

2. Assemble Cart

NOTE: We recommend at least 2 people to assemble grill.

- Turn the cart right side up. Then unfold the cart legs.

CAUTION: Do not stand, lean or apply pressure to the Cart Frame Bracket once assembly.

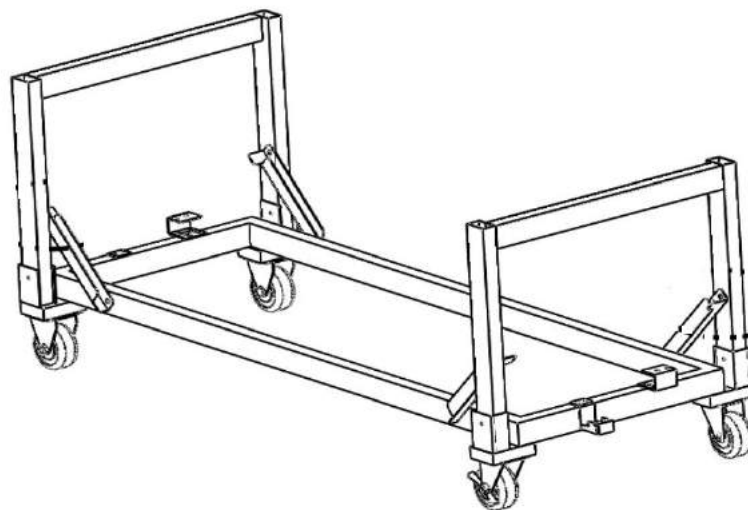

3. Install bottom gas tank holder

- Install gas tank Holder to both left and right lower bar of the cart frame and tightly secure with screw#AA.

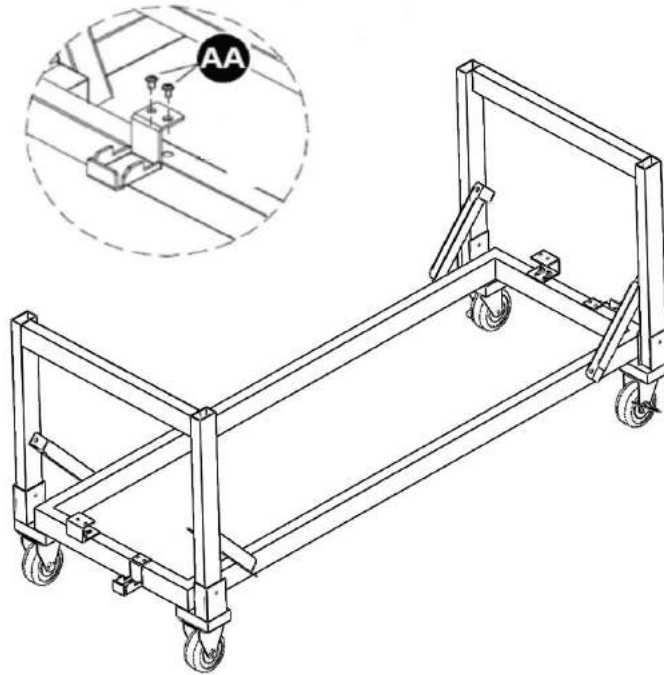

AA:4pcs

4. Install Handles

- Align both left and right handles onto the body of the grill. Then tighten the handles with bolt #DD as shown on diagram below.

Screw DD:8pcs

5. Install Grill Body

- Lift and position Fire Box Assembly to the Cart.
- All bottom four corners of grill body must be sitting on the SEAT on the cart beam.
- Then lock each leg by closing the latch of each buckle on legs and grill body.
- Warning: Always keep the latches locked.

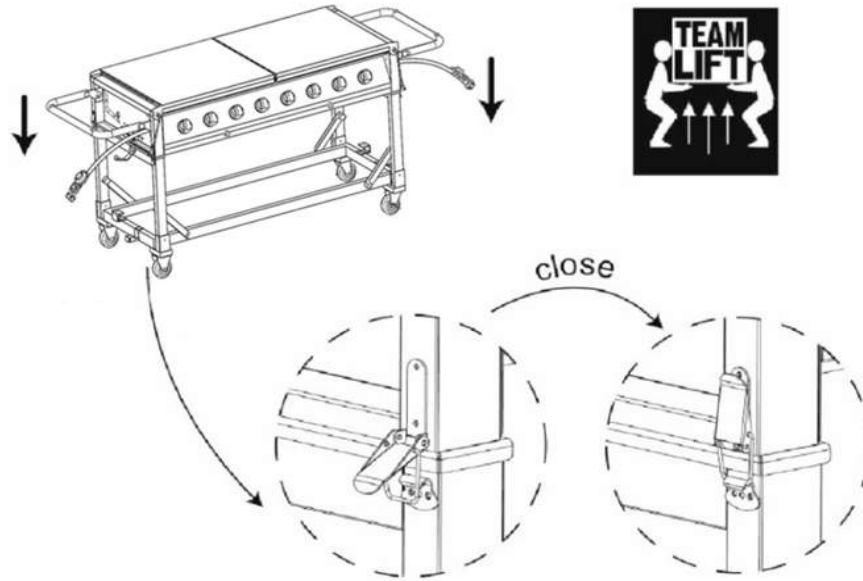

6. Install Grease Tray

- Position Grease Tray to the Holders on both left and right side of the cart.

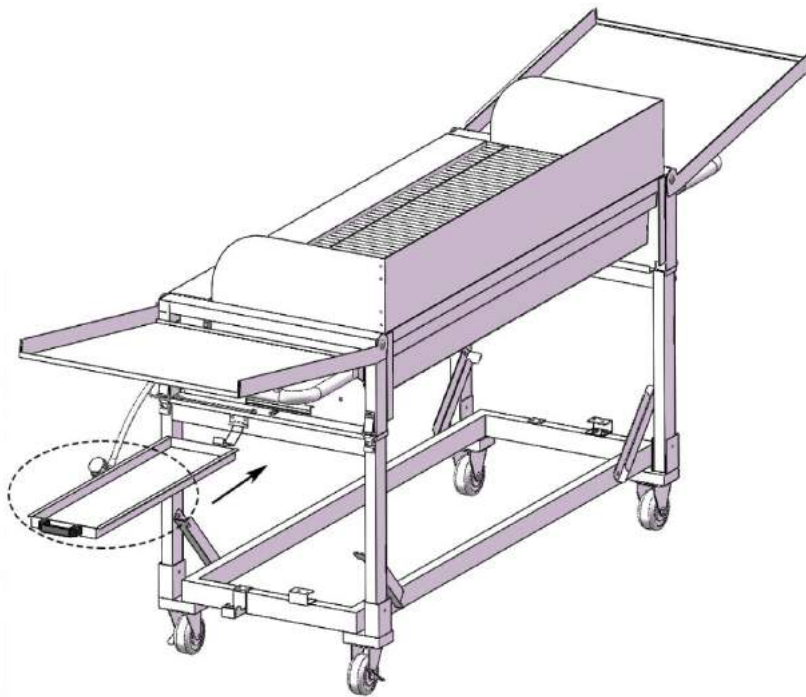

7. Install Windshield

- Open both left and right side shelf and insert the side handles (Shown on diagram 1).
- Open the wind shield (Shown on diagram 2).
- Unfold the left and right side panel of wind shield and insert the small flag on bottom edge of panel onto the slot on the grill body frame (Shown on diagram 3).

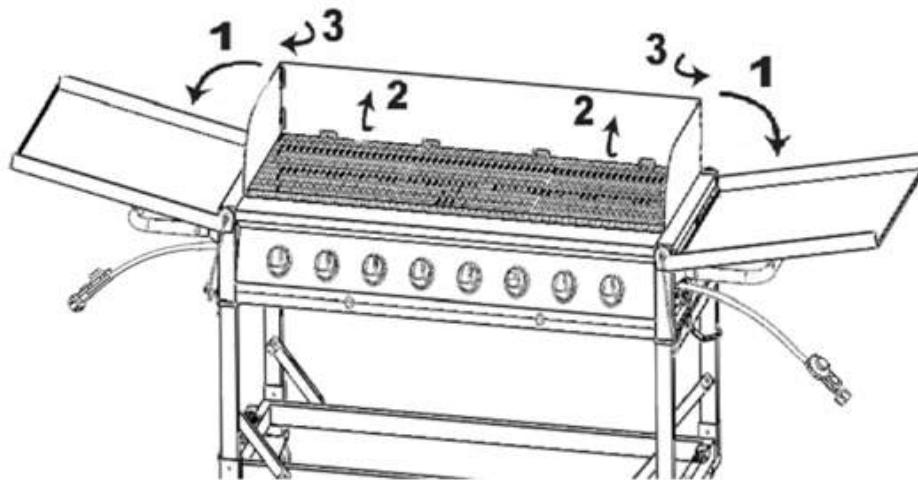

8. Install Flame tamer and Cooking grid.

- Place all the 8 Flame Tamers over the burners.
- Place all the 4 cooking grids over the Flame Tamer.

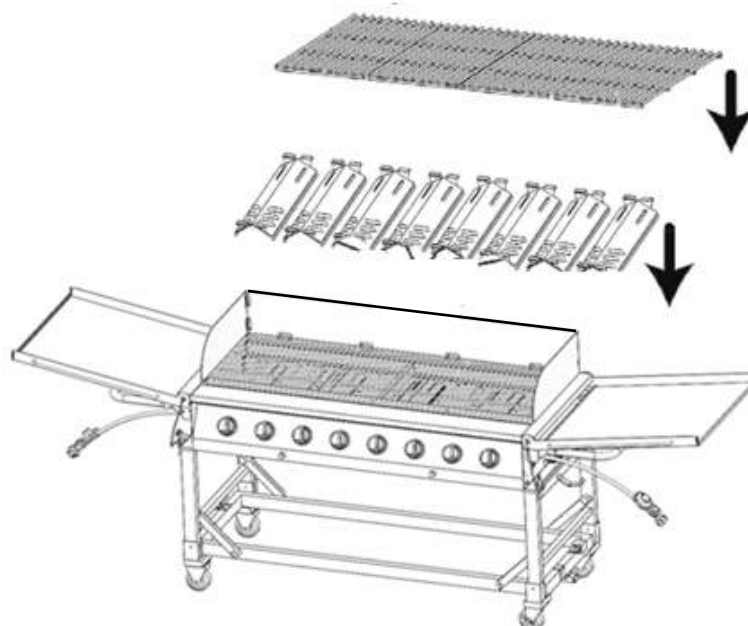
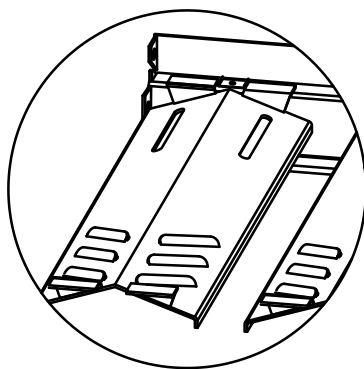

9. Install Main Lid Handle and Ignitor Battery

- Twist and remove Ignitor Cap from Control Panel
- Place 1 AA battery into the igniter body with + outward and – inward. (Battery not included)
- Install the igniter cap and spring over the + end of the battery and tightly screw it onto the control panel.
- Repeat the same steps for the igniter on the other side.
- Install the both left and right side handle to the cart with screw EE.

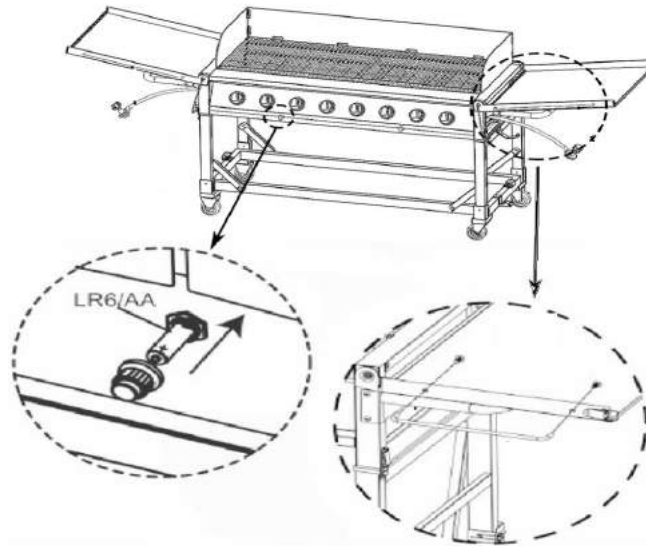

EE:4pcs

Electrode Check

NOTE: We recommend at least 2 people to perform the Electrode Check before proceeding
This test will ensure that the Spark Electrode Tips are properly positioned so your grill can easily ignite.

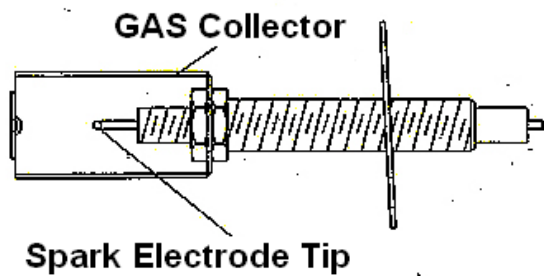

Tips prior to using grill

- Be sure all Control Knobs are set to “OFF” and open the Grill Lids.
- Have your assistant stand behind the right side of the grill and look toward the front of the grill. Never place your face inside the Grill.
- Press the Igniter Cap, You should hear a “clicking” sound. Your assistant should see a blue spark within each Gas Collector Box. If a spark is present Electrode Tips are properly positioned.
- If no spark is seen, the Spark Gap needs to be adjusted as follows:
 - a) If your not able to see a spark, the Spark Gap Electrode Tip and Receiver is more than 0.47 cm/ 3/16 in. off use long nose pliers to gently squeeze the Gas Collector Box to the narrow gap.
 - b) Recheck the Electrode again, if no “clicking” sound is heard; AA Battery is installed backwards.
 - c) Electric wires may be loose. Remove the AA Battery and inspect the Ignitor Junction Box found behind the Control Panel and reconnect any loose wires.

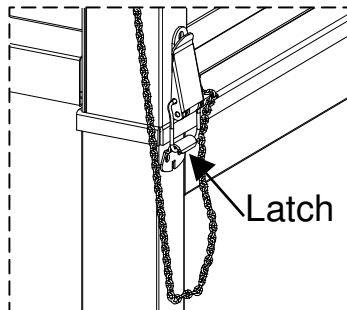

	<h1>WARNING</h1>	
<p>Failure to read and follow the Use and Care Instructions could result in a fire or explosion that could cause serious bodily injury, death or property damage.</p>		

Transporting or Storing your grill:

1. Lock grill Casters.
2. Remove LP Gas tank and Grease Tray from your grill.
3. Loosen 4 Latches on Grill Bowl and Cart. With an assistant. Lift and position Grill Bowl on a cardboard surface.
4. Lift up the 4 connect bracket shown on Fig.2 with your finger, then have the cart folded.
5. With an assistant, lift and position Grill Bowl onto the folded Cart. See Fig.3.
6. Then lock the Grill Bowl and Cart as Fig.4 shown.

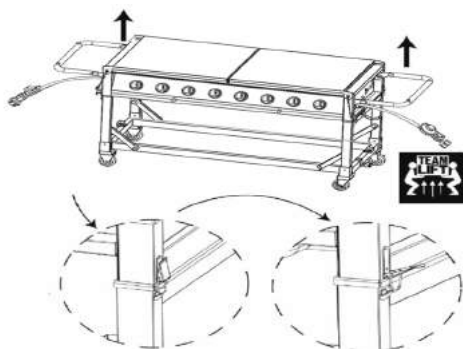

Fig.1

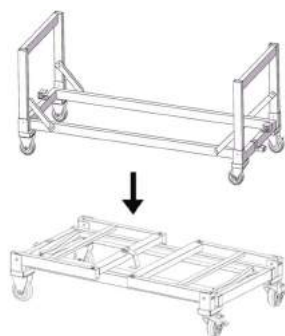

Fig.2

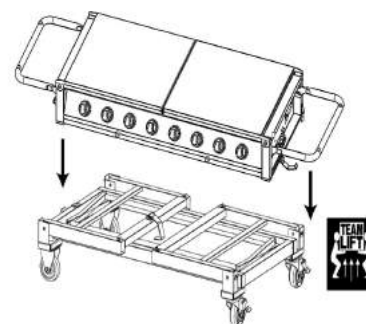

Fig.3

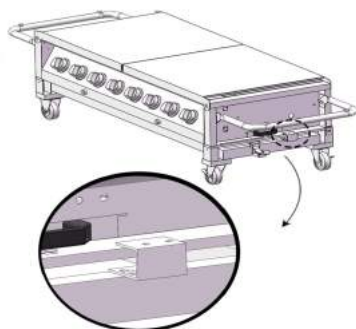

Fig.4

GB Assembly instructions

780-0838

Dear customer,

GB Congratulations on your purchase of this **Horeca Select** product.
Please take a few minutes before starting operation of the appliance and read the following operating instructions.

Many thanks.



USE OUTDOORS ONLY!
READ THE INSTRUCTIONS BEFORE USING THE APPLIANCE!
WARNING! ACCESSIBLE PARTS MAY BE VERY HOT. KEEP YOUNG CHILDREN AWAY!
THIS APPLIANCE MUST BE KEPT AWAY FROM FLAMMABLE MATERIALS DURING USE!
DO NOT MOVE THE APPLIANCE DURING USE!
TURN OFF THE GAS SUPPLY AT THE GAS CYLINDER AFTER USE!
DO NOT MODIFY THE APPLIANCE!



CONTENTS

INTENDED USE.....	12
SAFETY WARNINGS.....	12
SCOPE OF DELIVERY.....	13
ACCESSORIES.....	13
BEFORE FIRST USE.....	14
OPERATION.....	15
AFTER USE.....	17
TROUBLESHOOTING.....	17
CLEANING, MAINTENANCE AND REPAIR.....	18
STORAGE AND TRANSPORTATION.....	19
DISPOSAL.....	19
TECHNICAL DATA.....	20
WARRANTY.....	20

INTENDED USE

This barbecue is intended to grill different kinds of foodstuff in well-ventilated outdoor areas. The appliance must be operated with low pressure propane or butane liquefied petroleum gas (LPG). It may not be supplied with natural gas.
This appliance is intended for commercial or industrial use. It must not be used for any purposes other than those described to avoid personal injury or damage to property.

SAFETY WARNINGS

 **Read this instruction manual carefully before using the appliance. Familiarise yourself with the operation, adjustments and functions of switches. Internalise and follow the safety and operation instructions in order to avoid possible risks and hazards.**

 **Keep the instruction manual for future reference and provide to other when passing the appliance.**

GENERAL BARBECUE WARNINGS

1. **WARNING! Danger of carbon monoxide poisoning!** Never operate the appliance in enclosed areas such as garages or sheds, as this leads to a carbon monoxide build-up resulting in personal injury or death.
2. **WARNING! Danger of explosion!** Never operate the appliance in enclosed areas such as garages or sheds, as this leads to gas accumulation in case of a leakage which may result in an explosion.
3. Place the appliance on a secure level, stable and non-flammable surface, away from any heat source, prior to use.
4. Always lock the wheels with their brakes (if available) prior to use.
5. Do not move the appliance while it is in use.
6. Do not attempt to modify the appliance in any way. Only use attachments and accessories recommended by the manufacturer. Any alterations made to the appliance, improper use or non-compliance with the instructions lead to danger.
7. Do not use the appliance near flammable objects. Do not use under a pavilion, sun umbrella or the like. Keep distance of at least 3 m around the appliance to such objects.
8. Do not use the appliance in the immediate presence of aerosol cans, flammable liquids, volatile gases or other flammable substances. Keep open flames such as candles or torches away from the appliance.
9. Do not store any flammable liquids or volatile gases near the appliance.
10. Do not leave the appliance unattended during use.
11. Do not use liquid fuels with this appliance.
12. Never lean over cooking surface while lightening the appliance or during cooking.
13. This appliance is not intended to be used by persons (including children) with reduced physical, sensory or mental capabilities, or lack of experience and / or knowledge of the appliance and its properties, unless they have been given supervision or instruction concerning use of the appliance by a person responsible for their safety.
14. Supervise children at all times to ensure that they do not play with the appliance.

Assembly instructions

780-0838

GAS BARRBECUE WARNINGS

1. This appliance is configured to work with low pressure propane & butane liquefied petroleum gas (LPG). Do not use natural gas supply.
2. Open the cover(s) and fold up the wind screen before igniting the appliance.
3. Only cover the appliance when it has completely cooled off.
4. Never use charcoal or other solid fuels in this appliance.

GB

GAS CONNECTIONS / GAS CYLINDER / PRESSURE REGULATOR WARNINGS

1. Check the appliance and all connections regularly and each time the gas cylinder(s) is / are replaced for possible gas leaks (→Testing for gas leaks).
2. Never check for gas leaks using a match or any other open flame.
3. Never alter or modify the pressure regulator(s) or gas supply assembly.
4. Always turn the gas supply off on the gas cylinder(s) and / or the pressure regulator(s) and disconnect the gas hose(s) after use.
5. Never store gas cylinders indoors or close to heat sources.
6. Always store gas cylinders in upright position, never in horizontal position. This could cause the gas cylinder to leak or gas could leak into the gas hose.
7. Never use the appliance without the pressure regulator(s).
8. Only use pressure regulators approved for liquid petroleum gas (LPG) and complying with national regulations. Observe the technical data (→ TECHNICAL DATA).

GAS HOSE WARNINGS

1. Inspect the gas hose(s) prior and after each use - look for any cuts, cracks excessive wear or other damage. Let the gas hose(s) be replaced every one to two years by a qualified technician or the retailer only. Have brittle gas hoses and their connections exchanged. In case of doubts, ask a local specialist.
2. Protect the gas hose(s) against damages. Do not let it / them hang over sharp edges, do not twist, squeeze or bend it / them. Keep the gas hose(s) away from hot surfaces and ensure that nobody can trip over it / them.
3. Only use a gas hoses approved for liquid petroleum gas (LPG) and complying with national regulations. Observe the technical data (→ TECHNICAL DATA).
4. Every kind of work or replacement of the hoses is to be conducted according to manufacturer's instruction, by qualified personal or specialists.

IF YOU SMELL GAS

1. Never light the appliance if you smell gas.
2. Immediately turn the gas supply off on the appliance as well as on the gas cylinder(s) and / or the pressure regulator(s).
3. Extinguish all open flames near the appliance, such as candles or torches. Switch all electric appliances in the surrounding off.
4. Make sure the area is well-ventilated with fresh air.
5. Do not use the appliance any longer and have it repaired by an authorized professional only, should it still smell of gas.

BATTERY WARNINGS

1. Keep batteries out of reach of children at all times.
2. Seek immediate medical advice if batteries have been swallowed.
3. Handle leaking batteries with proper protection and dispose them of accordingly. Prevent battery acid from coming into contact with skin and eyes. If you do get battery acid in your eyes or mouth, flush them thoroughly with lots of water and seek medical advice immediately. If battery acid comes into contact with your skin, wash the affected area with lots of water and soap.
4. Clean the contacts on batteries and the appliance prior to inserting.
5. Do not use old and new batteries, batteries of different types or different manufacturers together. Always replace all batteries of a set at the same time.
6. Only use batteries recommended for this appliance. Observe the technical data (→ TECHNICAL DATA) stated within this instruction manual.
7. Observe the polarity (+ and -) when inserting batteries. Pay attention to the markings on the appliance and the battery.
8. Remove batteries from the appliance if it is not to be used for an extended period of time.
9. Remove exhausted batteries promptly from the appliance.
10. Do not attempt charging non-rechargeable batteries.
11. Never expose batteries to extreme environmental conditions like heat, cold or moisture.
12. Do not dismantle, open or shred batteries.
13. Do not short-circuit batteries. Do not store them haphazardly in a place where they may short-circuit each other or be short-circuited by other metal objects.

SCOPE OF DELIVERY

Refer to the illustration pages in the front section of this instruction manual for details.

Make sure the scope of delivery is complete and free of any damage. Contact the dealer from whom you purchased the appliance if you find that parts are missing or show damage (→ WARRANTY).

Do not use the appliance unless missing parts have been delivered in addition or defective parts have been replaced.

Using an incomplete or damaged appliance leads to personal injury und property damage.

ACCESSORIES

To operate this appliance safely and correctly, some accessories, i. e. tools and attachments, are necessary. Refer to the illustration pages in the front section of this instruction manual for details.

Ensure that you have the accessories and tools needed for commissioning and operation available. This also includes suitable personal protective equipment.

Accessories and tools are available through your authorised dealer. When buying always consider the technical requirements of this appliance (→ TECHNICAL DATA).

If you are not certain, ask a qualified specialist and get advice from your trusted dealer.



NOTE: This instruction manual contains information and suggestions for several attachments and their uses. The attachments depicted are not necessarily included in the shipment, but are meant to indicate additional possibilities for using this appliance.

GB Assembly instructions

780-0838

BEFORE FIRST USE

GB

UNPACKING

1. Unpack all parts and lay them on a flat, stable surface.
2. Remove all packing materials and shipping devices (if applicable).



WARNING!

The appliance and the packaging are not children's toys! Children must not play with plastic bags, sheets and small parts! There is a danger of choking and suffocation!

ASSEMBLING

1. Assemble the appliance completely and make all required adjustments prior to operation.
2. Follow the assembly and operation instructions closely. Use the figures as visual guide.
3. Pay attention to small parts such as screws and nuts that are loosened or removed for assembly or during adjustments. Keep them safe in order to avoid losing them.
4. The appliance is large. Assemble with two people.



WARNING!

Use the appliance only after it has been completely assembled and adjusted!

Choosing gas

1. Propane gas cylinders can be used throughout the entire year. Butane gas cylinders work best during the summer. They are distinctly less efficient at temperatures under +10 °C.
2. We recommend using either 5 kg or 11 kg gas cylinders, for best performance.
3. Do not allow cylinders to be filled beyond 80% capacity. Over-filled cylinders can create a dangerous condition due to build-up pressure and cause the valve to expel propane gas vapours. The vapour is combustible and if it comes in contact with a spark source or flame an explosion causing severe burns, bodily harm, or death could occur.
4. Always use a protective cylinder cap when appliance is not connected to the cylinder(s).

Gas connections



WARNING! Be aware of flashback!

Make sure there is no debris, spiders, small insects or webs inside the head of the gas cylinder(s), pressure regulator(s), burner(s), burner tube(s) or hose(s), before any connection is made. They can obstruct the gas flow, which could result in a fire in and around the burner tube. This kind of fire is known as "flash-back" and can cause serious damages. Check and clean (→ CLEANING, MAINTENANCE AND REPAIR) all the parts of the appliance before assembling it, to reduce the chance of its occurrence.

Connecting / exchanging gas cylinders



WARNING!

Only use the provided or equivalent pressure regulator(s) (→ TECHNICAL DATA) in order to guarantee that it functions safely and efficiently. Using an improper or a defective pressure regulator is dangerous. Consult your specialised dealer concerning suitable pressure regulators. The type of the pressure regulator to be used must indicate that it complies with the relevant standard and requirement (EN 16129).

Consult your local gas retailer regarding suitable gas cylinders and pressure regulators (→ TECHNICAL DATA).



NOTE: Gas connections are equipped with left handed threads; the screw-nut needs to be turned counter clockwise!

1. Ensure that there are no ignition sources like cigarettes, open flames, sparks and other heat sources nearby when connecting or replacing gas cylinders.
2. Place the gas cylinder(s) on level ground next to the appliance.
3. Make sure that all control knobs on the appliance are in the off positions **ARRÊT/OFF**.
4. Make sure that the gas valve of the gas cylinder(s) and / or the pressure regulator(s) is / are closed.
5. Connect the gas hose(s) to the gas line(s) of the appliance (Fig. 1). Do not overtighten the connections. Use only the delivered hardware to secure the connections. Do not use sealing tape or a liquid sealant.
6. Connect the / each pressure regulator to the gas cylinder inlet(s) by turning the pressure regulator counter clockwise (Fig. 2). Secure the connection(s) with the retention nut(s).
7. Connect the other end of the gas hose(s) to the pressure regulator(s) (Fig. 3).
8. Check all connection for gas leaks (→ Testing for gas leaks).

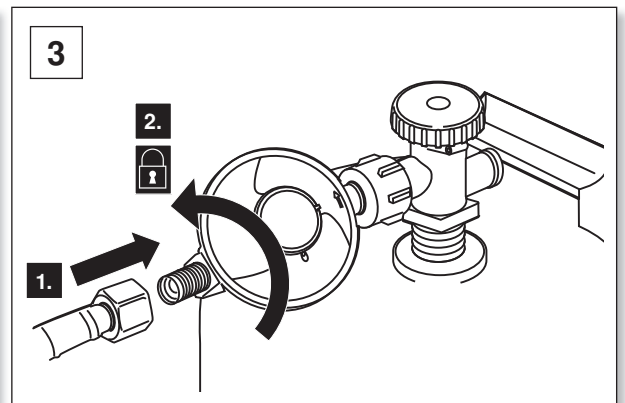
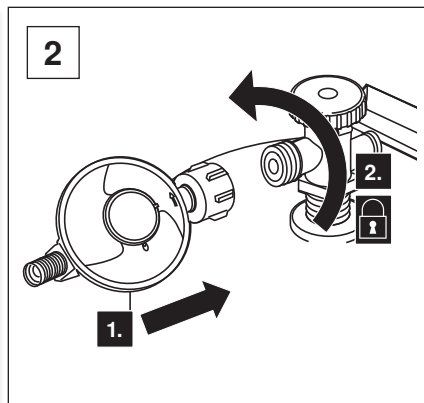
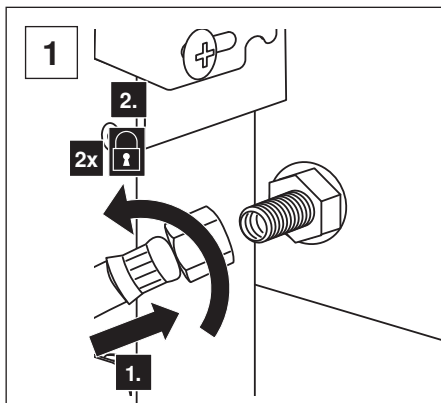

GB Assembly instructions

780-0838

Testing for gas leaks

**WARNING! Risk of explosion!**

Never check for gas leaks using a match or any other open flame.

GB

Test all connections, fittings and all gas hoses for gas leaks every time prior use of the appliance, or each time the gas cylinder(s) is / are changed. Make sure this procedure is carried out in a well ventilated area away from flames, sparks or any heat sources. Do not attempt to light the appliance, if you smell gas.

1. Make sure that all control knobs on the appliance are in the off positions **ARRÊT/OFF**.
2. Open the gas valve of the gas cylinder(s) and / or the pressure regulator(s).
3. Apply leak detector spray or half water / half soap solution with a brush to all the connection points.
4. Turn the gas supply on the valve of the gas cylinder(s) and or the pressure regulator(s) off immediately, if you spot gas bubbles forming on the interested areas. Tighten all connections again and repeat the test.
5. Do not use the appliance but contact your retailer, if gas bubbles keep forming.

Inserting / exchanging batteries

This appliance is equipped with two battery operated electronic ignitors, sparking the electrodes of a group of four burners (left and right) at once.

1. Remove the cap of each electronic ignitor by turning it counter-clockwise (Fig. 1).
2. Insert one LR6/AA battery into the tube (Fig. 2). Observe correct polarity (+ and -)!
3. Screw the cap back on clockwise (Fig. 3).

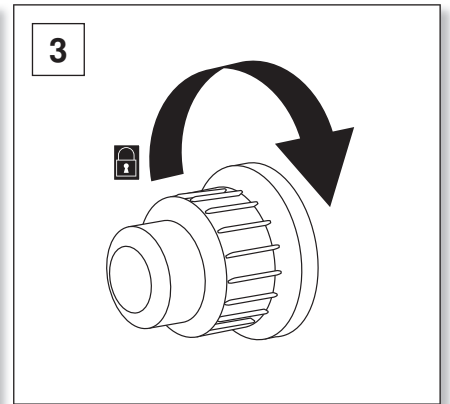
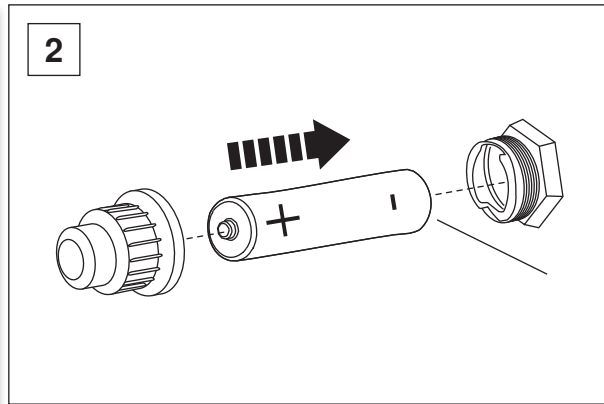
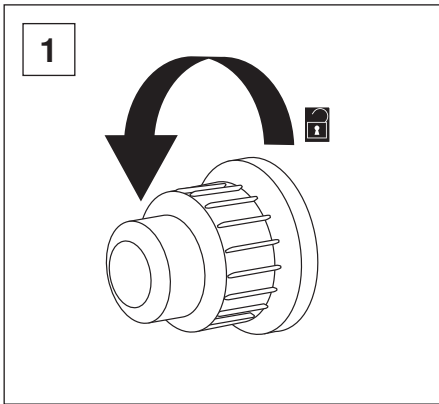

Burning-off

**WARNING!**

Use the appliance only after it has been completely erected! Do not use it in collapsed position!

**WARNING!**

Use the appliance only with the firebox fixed and secured to the substructure! Do not use it without substructure!

**WARNING!**

Use the appliance only after the wind screen has been properly unfolded and secured! Do not use it with folded wind screen!

Before first use, remove any production residue and clean the appliance:

1. Operate the appliance at high temperature with the wind shield folded up for about 10 - 15 minutes to burn-off production residues (→ IGNITING THE BURNER(S)).
2. Turn the appliance off; allow it to cool and clean all parts (→ CLEANING AND CARE) afterwards.

OPERATION

**WARNING! Danger of burns!**

This appliance generates heat and escaping steam during use! Take proper precautions to prevent risk of burns, fires, or other damages to people and property! Wear protective oven mittens or gloves. Use proper tools like barbecue tong and prongs to turn over grillables!

COOKING TIPS

1. Brush the grill grates with cooking or vegetable oil, before using the appliance. Use a brush with a long handle. The juices from the food drip onto the heater during cooking and vaporise. The steam arising from this process contributes to the taste of the food.
2. Set the control knob(s) to the desired temperature in order to reach your desired cooking results.

IGNITING THE BURNER(S)

The burner(s) can be ignited with the built-in electronic ignitor(s) or alternatively manually with a match. Follow the procedure for each method as described below.

**WARNING! Risk of explosion!**

Always ignite the burner(s) within **5 seconds** after turning the control knob to a position in between **HI** and **LO**. Gas can collect inside the appliance causing an explosion on ignition.

GB Assembly instructions

780-0838



WARNING!

If any burner still does not ignite after a few tries, it could indicate a problem with the gas supply. Turn the gas supply off on the appliance as well as on the gas cylinder(s) and / or the pressure regulator(s). Do not use the appliance until the cause of the problem has been found (→ TROUBLESHOOTING).

Igniting the main burner(s) with the electronic ignitor(s)

1. Wait **5 minutes** after all connections are made and make sure no gas is leaking (→ Testing for gas leaks).
2. Open the cover(s) of the appliance and fold up the wind screen. Refer to the illustration pages in the front section of this instruction manual for details. Turn all control knobs to the off positions **ARRÊT/OFF** (Fig. 1).
3. Open the valve of the gas cylinder(s) and / or the pressure regulator(s) (Fig. 2).
4. Keep your face and body as far away from the appliance as possible while igniting.
5. Push and turn the control knob of the selected burner to the **HI** position (Fig. 3). Push and hold the button of the electronic ignitor until the selected burner lights up. The electronic ignitor sparks all electrodes of the selected burner group at once.
6. Set the control knob between **HI** and **LO** position (Fig. 4), to adjust the heat.
7. Ignite the other burner(s) using their respective control knob(s), after the first burner has fired up.



WARNING!

Turn all the control knobs to the off positions **ARRÊT/OFF**, if any burner does not ignite within **5 seconds**. Wait for **5 minutes** to let the gas dissipate and try again.

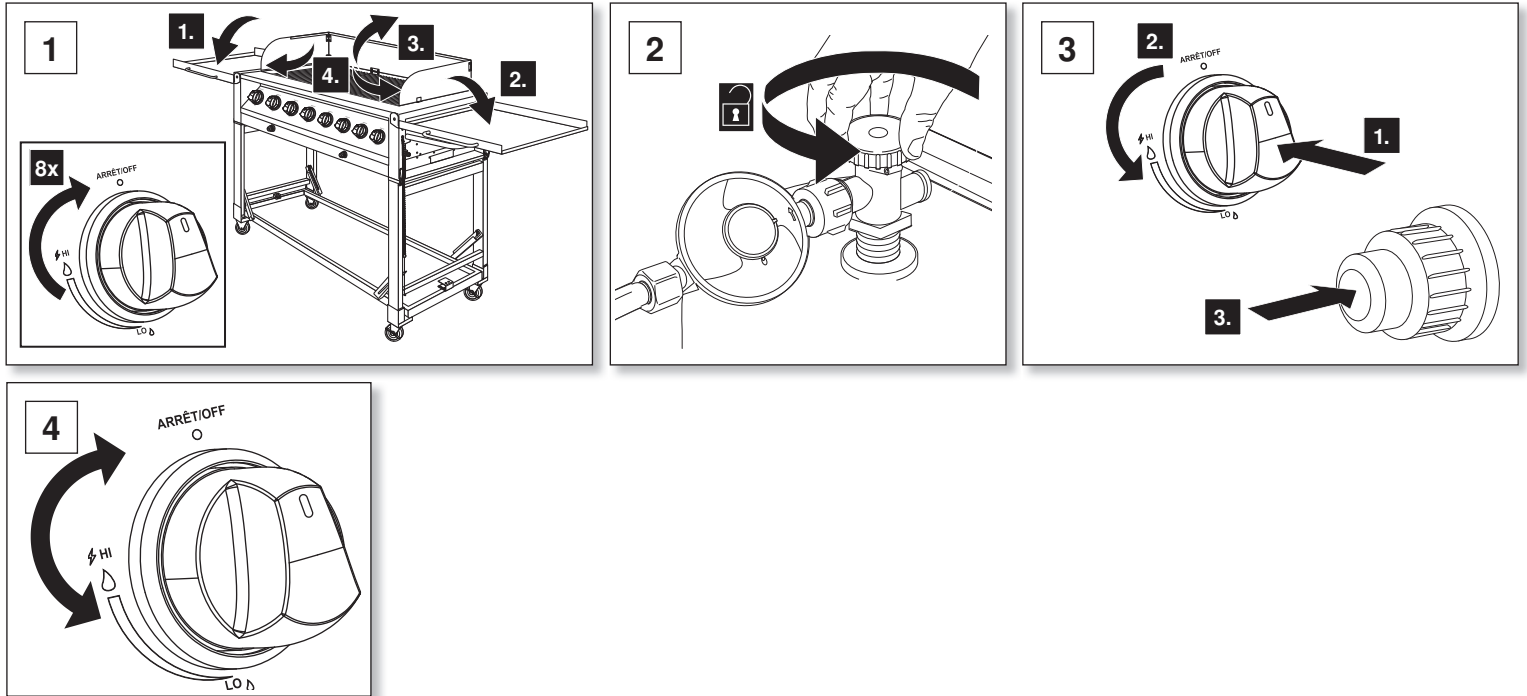

Igniting the main burner(s) with a match

1. Wait **5 minutes** after all connections are made and make sure no gas is leaking (→ Testing for gas leaks).
2. Open the cover(s) of the appliance and fold up the wind screen. Refer to the illustration pages in the front section of this instruction manual for details. Turn all control knobs to the off positions **ARRÊT/OFF** (Fig. 1).
3. Open the valve of the gas cylinder(s) and / or the pressure regulator(s) (Fig. 2).
4. Keep your face and body as far away from the appliance as possible while igniting.
5. Insert a long stick match into the match holder (Fig. 3).
6. Light the match and insert it into the match lighting hole on the left / right side of the firebox (Fig. X). Push and turn the control knob of the selected burner to the **HI** position (Fig. 5).
7. Set the control knob between **HI** and **LO** position (Fig. 6), to adjust the heat.
8. Ignite the other burner(s) using their respective control knob(s), after the first burner has fired up. Push and turn the control knob(s) and set it to the **HI** position to ignite it. The first burner will ignite the nearby burner through cross-lighting.



WARNING!

Turn all the control knobs to the off positions **ARRÊT/OFF**, if any burner does not ignite within **5 seconds**. Wait for **5 minutes** to let the gas dissipate and try again.

GB Assembly instructions

780-0838

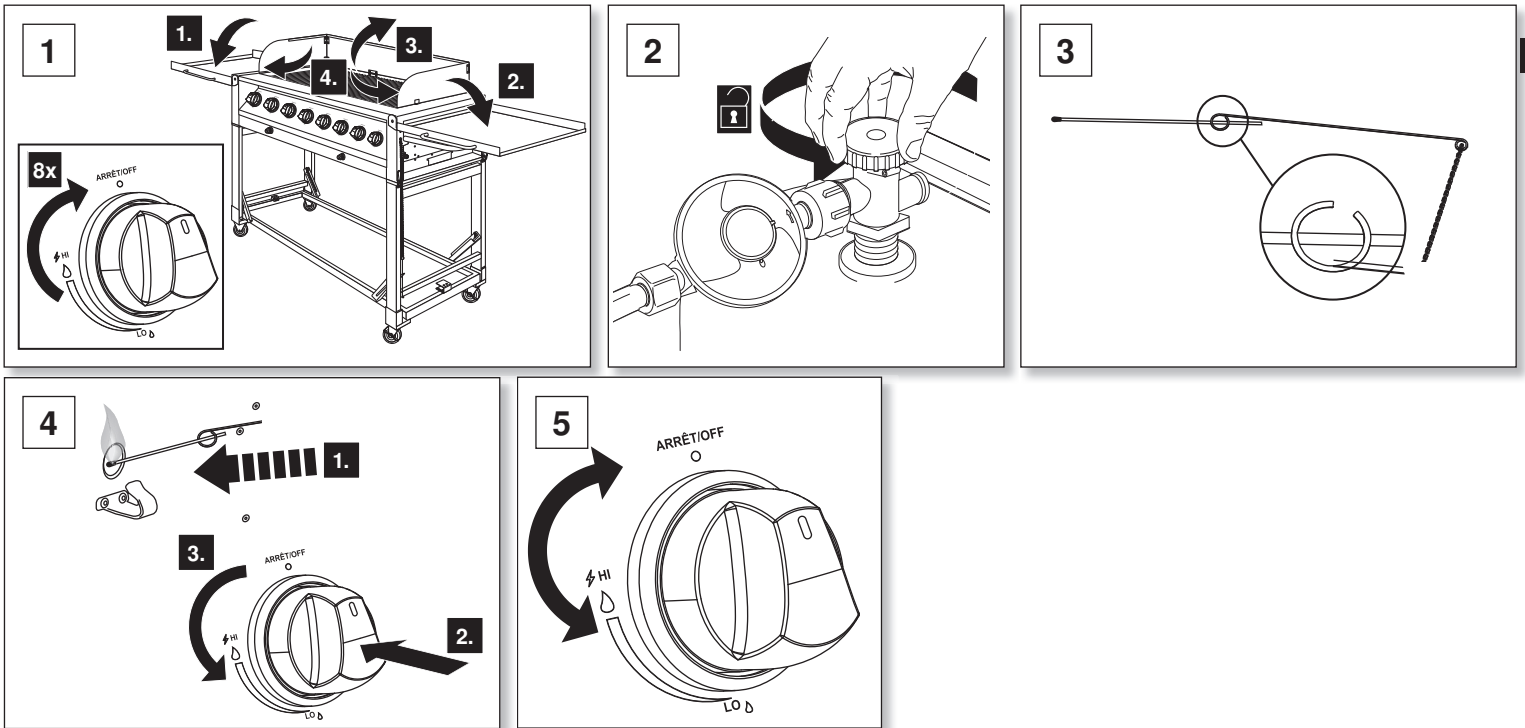

APPEARANCE OF THE FLAME

- The flame should appear blue and stable (Fig. 1). There should be no yellow sparks, loud noises nor should there be distance between the base of the flame and the nozzle.
- A yellow flame indicates insufficient oxygen supply. Loud noises and the flame being distant from the nozzle indicate excessive oxygen supply.
- Check the appearance of the flame at every use. Contact a specialist to reset the appliance, should the appearance differ from normal.

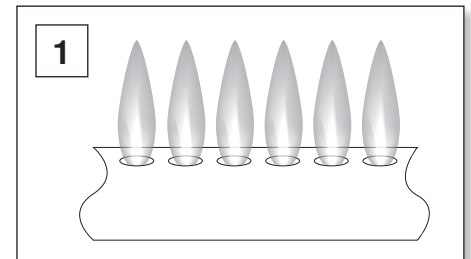

TIPS REGARDING BURNING GREASE



WARNING!

Protect yourself and your hands from spurts of flames. Never try to put out a grease fire with water! Turn all the control knobs to the off positions **ARRÊT/OFF**, if a grease fire occurs. Turn the gas supply on the gas cylinder(s) and / or the pressure regulator(s) off and wait until the fire goes out by itself.

- Grease and juice that drips from meat onto the heater produces short spurts of flames which also contribute to the grilling taste.
- If too many spurts of flames are produced, the meat could burn.
- Only use meat that is suitable for grilling. Try to avoid grilling meat with excessive fat.
- Cut away as much fat as possible and do not overuse marinade to prevent meat from burning, before grilling meat.

AFTER USE

1. Close the valve on the gas cylinder(s) and / or the pressure regulator(s), wait until the flame extinguishes completely in the appliance.
2. Turn all the control knobs to off positions **ARRÊT/OFF** and let the appliance cool for about **5 minutes**. The cover(s) must be open at this time.
3. Disconnect the gas cylinder(s) from the appliance, clean and store the appliance (→ CLEANING, MAINTENANCE AND CARE), if you do not plan to use the appliance again soon.

TROUBLESHOOTING

Suspected malfunctions, errors or damage are often due to causes that the users can fix themselves. Therefore check the appliance using below table before contacting a qualified specialist. In most cases the problem can be solved quickly.



WARNING!

Only perform the steps described within this instruction manual! All further inspection, maintenance and repair work must be performed by an authorised service centre or a similarly qualified specialist!

GB Assembly instructions

780-0838

Problem	Possible cause and solution
GB The appliance does not ignite immediately.	<ul style="list-style-type: none">• Ensure that the gas valves are open.• Check if sparks are produced when igniting the appliance.• Push the control knob(s) for 5 seconds before you attempt to ignite the appliance.• Ensure that the burner(s) is / are clean.• Check if the gas cylinder(s) is / are not empty.
The appliance does not ignite at all.	<ul style="list-style-type: none">• The electrode maybe covered with cooking residues. Use a clean swab and alcohol to clean.• The electrode or wire may be damaged. Replace with a new electrode assembly with wire.• The wires of the electrode are loose or fell off. Replace with a new electrode assembly with wire.• Clear the orifice if blocked.• The electrode does not aim at burner hole. Align the electrode and the burner hole. Adjust the distance between metal pin of the electrode and burner hole to 3 - 5 mm.
No spark noise.	<ul style="list-style-type: none">• Ignitor battery is empty. Replace the battery.• The electrode does not aim at the burner hole. Align the electrode and the burner hole. Adjust the distance between metal pin of the electrode and burner hole to 3 - 5 mm.
Pressure regulator makes noise.	<ul style="list-style-type: none">• Check if the ventilation opening on the pressure regulator is plugged. Unplug the opening and wait 5 minutes before starting again.• Check if the ventilation openings are covered up. Check the appearance of the flames and remove possible plugging.
The appliance only heats up from 100 °C to 150 °C; low heat with knob(s) in HI position.	<ul style="list-style-type: none">• Check all gas connections for gas leaks. If there is a gas leak, tighten the connection.• Straighten up the gas hose(s) if bent or kinked• Clear the burner(s) or the orifice if blocked.• Have your gas dealer check the gas cylinder(s), in case of low gas pressure.• Gas supply is not sufficient as there is not enough gas in the gas cylinder(s). Refill or replace the gas cylinder(s).
The appliance takes a long time to heat up.	<ul style="list-style-type: none">• The appliance takes longer to heat up when it is cold outside. The time required to heat from 250 °C to 320 °C is usually about 10 - 15 minutes.• Gas supply is not sufficient as there is not enough gas in the gas cylinder(s). Refill or replace the gas cylinder(s).• Check if the gas hose(s) is / are blocked or clogged.
The burner flame is not blue.	<ul style="list-style-type: none">• Check if there is too much or too little air being supplied.• Check if the burner is misaligned.• In case of incomplete combustion contact specialist.
Burner(s) cannot be ignited by match.	<ul style="list-style-type: none">• Open the valve of the gas cylinder(s) and / or the pressure regulator(s), if no gas is being fed to the burner(s).• Clear the tubes of the burner(s) if the gas flow is not smooth.• Re-assemble burner(s) and valve(s) if you deem the assembly to be incorrect.• WARNING! Turn all the control knobs to the off positions ARRÊT/OFF, if any burner does not ignite within 5 seconds. Wait for 5 minutes to let the gas dissipate and try again.
Flare-up.	<ul style="list-style-type: none">• Excessive fat content in the meat, remove part of the fat before grilling.• Reduce the temperature.• Clean if you spot deposits of grease.
Flame rising from the burner.	<ul style="list-style-type: none">• Excessive gas pressure, contact your gas dealer.

CLEANING, MAINTENANCE AND REPAIR



WARNING!

Always switch the appliance off and let it cool down before performing inspection, maintenance and cleaning work!
Do not immerse burner(s) into water or other liquids. If they become wet, let them dry thoroughly and check the function afterwards.

Cleaning

1. Clean the appliance after each use with a slightly damp cloth and a little soap. Use a brush for hard to reach places.
2. Remove stubborn dirt with high pressure air (max. 3 bar).



NOTE: Do not use chemical, alkaline, abrasive or other aggressive detergents or disinfectants to clean this appliance as they might be harmful to its surfaces.

GB Assembly instructions

780-0838

Stainless steel surfaces

1. Wipe all stainless steel surfaces with a wet soft cloth. Use a mild detergent to remove grease.
2. Remove grease and food remains from the fire box with a plastic or wooden spatula.
3. Remove the burner(s), before cleaning the fire box.

GB

Grease tray(s)

1. Avoid that the grease tray(s) overflow(s). Empty regularly during use.
2. Clean the grease tray(s) after each use using warm water and a mild detergent.



NOTE: Add sand or cat litter to the grease tray(s) before use to avoid that the grease sticks on the surface.

MAINTENANCE

Before and after each use, check the appliance or accessories or attachments for wear and damage. If required, exchange them for new ones as described in this instruction manual. Observe the technical requirements (→ TECHNICAL DATA).

Burner

1. A conversion to a different gas type must be done by qualified personnel or your retailer only.
2. Clean the burner(s) at least once per year or whenever they get dusty.
3. Make sure that no dust or insects get inside the burner(s) openings or the air intake.
4. Clean the burner(s) with a pipe cleaner. Use a wire brush to clean any rust from the surface of the burner(s).
5. Make sure that the valve outlets of the valve unit are placed exactly in the air funnels of the / each burner, when assembling the appliance.
6. Perform a visual check of the burner(s) flames regularly, do as follows:
 - a. Remove cooking grids and flame tamers.
 - b. Light the burner(s).
 - c. Turn control knob(s) from **LO** to **HI**. Check the flame status, the flame in **LO** position should be smaller than in **HI** position, as figure shown below.

Always check flame before each use, if anything seems out of the ordinary (→ TROUBLESHOOTING).

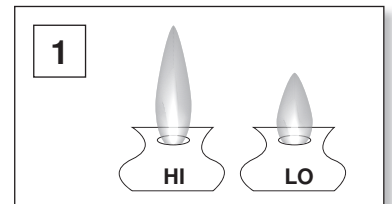

REPAIR

This appliance does not contain any parts that can be repaired by the consumer. Contact a qualified specialist to have it checked and repaired.



WARNING!

Always make sure all safeguards, if available, have been reinstalled safely and correctly after each cleaning or maintenance! Never use the appliance without its safeguards!

STORAGE AND TRANSPORTATION

STORAGE

1. Switch the appliance off and remove the batteries.
2. Clean the appliance as described above.
3. Cover the burner(s) with aluminium foil so that no dust or insects collect inside.
4. Collapse the substructure and secure the fire box. Refer to the illustration pages in the front section of this instruction manual for details.
5. Cover the appliance with the hood cover to protect it against dust.
6. Disconnect the gas cylinder(s) and store it in an outdoor location. Make sure that the gas cylinder(s) is / are not stored near heat sources or in direct sunlight.
7. Do not store a spare gas cylinder under or near this appliance.
8. Store the appliance and its accessories in a dry, frost-free place. The ideal storage temperature is between 10 °C and 30 °C.
9. Always store the appliance in a place that is inaccessible to children.
10. Clean the appliance itself and the burner(s) thoroughly before use, if the appliance has been stored for a long period of time.

TRANSPORTATION

1. Switch the appliance off and remove the batteries.
2. Make sure the fire box is secured with its latches and the retaining wing nuts of the leg support of the substructure are properly tightened, when moving the appliance on casters. Refer to the illustration pages in the front section of this instruction manual for details.
3. Ensure the fire box is secured with the transportation clamps, when transporting the appliance collapsed.
4. Attach transportation guards, if applicable.
5. Always push or pull the appliance by its handle / gripping surfaces.
6. Protect the appliance from any heavy impact or strong vibrations which may occur during transportation in vehicles.
7. Secure the appliance to prevent it from slipping or falling over.

DISPOSAL



Environmental Protection

Discarded electric appliances are recyclable and should not be discarded in the domestic waste! Please actively support us in conserving resources and protecting the environment by returning this appliance to the collection centres.



Do not put your used batteries, nickel cadmium, rechargeable, round cell or starter batteries in with your household rubbish. Take them to an appropriate disposal/collection site.

Pb Cd Hg

GB Assembly instructions

780-0838

TECHNICAL DATA

GB

Power supply (control knob illumination)	1.5 V  (LR6/AA battery x2) (not included)			
Nominal heat input	Main burner(s) (x8): 4.2 kW Total: 33.6 kW	Gas consumption	Butane: 2443 g/h Propane: 2400 g/h	
Cooking area (W x D)	123.0 x 49.0 cm			
Cooking height (H)	89.5 cm			
Dimensions folded (H x D x W)	92.0 x 65.0 x 140.0 cm			
Dimensions unfolded (H x D x W)	108.5 x 65.0 x 260.0 cm			
Max. length gas hose	1.5 m (for Finland only 1,2 m)			
Appliance category	I3+ (28-30/37)	I3B/P (30)	I3B/P (50)	I3B/P (37)
Gas type and pressure	Butane at 28-30 mbar / propane at 37 mbar	G30 (Butane), G31 (Propane) and their mixtures at 28-30 mbar	G30 (Butane), G31 (Propane) and their mixtures at 50 mbar	G30 (Butane), G31 (Propane) and their mixtures at 37 mbar
Main burner(s) orifice size	Ø 1.02 mm	Ø 1.02 mm	Ø 0.89 mm	Ø 0.95 mm
Destination country	BE, CH, CY, CZ, ES, FR, GB, GR, IE, IT, LT, LU, LV, PT, SI, SK, TR	BE, BG, CY, CZ, DK, EE, FI, FR, GB, GR, HR, HU, IT, LT, LU, LV, MT, NL, NO, RO, SE, SI, SK, TR	AT, CH, CZ, DE, LU, SK	PL
Pressure regulator type	included for different destination countries (→ PRESSURE REGULATOR TYPES)			

PRESSURE REGULATOR TYPES

Destination country	Pressure regulator type	Gas pressure [mbar]	Gas consumption [kg/h]
BG	A235is	29	1.5
PT		30	
ES	A300i-A310i	30	
RU		30	
RO		30	
NL		30	
HU		28	
IT		37	
PL		37	
BE		37	
DE	30/50	30/50	
AT			

LIMITED WARRANTY

DURO warrants to the original consumer-purchaser only that this product (Model #780-0838) shall be free from defects in workmanship and materials after correct assembly and under normal and reasonable home use for the periods indicated below beginning on the date of purchase. The manufacturer reserves the right to require photographic evidence of damage, or that defective parts to be returned, postage and or freight Pre-paid by the consumer, for review and examination.

Stainless steel tube burners: 3 years warranty.

Flame tamers: 2 years LIMITED warranty; does not cover dropping, chipping, scratching, or surface damage.

Cooking grids: 2 Years LIMITED warranty; does not cover dropping, chipping, scratching, or surface damage.

All other parts: 1 Years LIMITED warranty (Includes, but not limited to, valves, frame, housing, cart, control panel, igniter, regulator, hoses); does not cover chipping, scratching, cracking surface corrosion, scratches or rust.

Upon consumer supplying proof of purchase as provided herein, Manufacturer will repair or replace the parts which are proven defective during the applicable warranty period. Parts required to complete such repair or replacement shall be free of charge to you except for shipping costs, as long as the purchaser is within the warranty period from the original date of purchase. The original consumer-purchaser will be responsible for all shipping charges of parts replaced under the terms of this limited warranty. This limited warranty is applicable in the United States only, is only available to the original owner of the product and is not transferable.

Manufacturer requires reasonable proof of your date of purchase. Therefore, you should retain your sales receipt and/or invoice. If the unit was received as a gift, please ask the gift-giver to send in the receipt on your behalf, to the below address. Defective or missing parts subject to this limited warranty will not be replaced without registration or proof of purchase. This limited warranty applies to the functionality of the product ONLY and does not cover cosmetic issues such as scratches, dents, corrosion or discoloring by heat, abrasive and chemical cleaners or any tools used in the assembly or installation of the appliance, surface rust, or the discoloration of stainless steel surfaces. Surface rust, corrosion, or powder paint chipping on metal parts that does not affect the structural integrity of the product is not considered a defect in workmanship or material and is not covered by this warranty. This limited warranty will not reimburse you for the cost of any inconvenience, food, personal injury or property damage. If an original replacement part is not available, a comparable replacement part will be sent. You will be responsible for all shipping charges of parts replaced under the terms of this limited warranty.

AUSTRALIA: Our goods come with guarantees that cannot be excluded under the Australian Consumer Law. You are entitled to a replacement or refund for a major failure and for compensation for any other reasonable foreseeable loss or damage. You are also entitled to have the goods repaired or replaced if the Goods fail to be of acceptable quality and the failure does not amount to a major failure.

ITEMS MANUFACTURER WILL NOT PAY FOR:

- Service calls to your home.
- Repairs when your product is used for other than normal, single-family household or residential use.
- Damage resulting from accident, alteration, misuse, lack of maintenance/cleaning, abuse, fire, flood, acts of God, improper installation, and installation not in accordance with electrical or plumbing codes or use of products not approved by the manufacturer.
- Any food loss due to product failures.
- Replacement parts or repair labor costs for units operated outside the United States or Canada.
- Pickup and delivery of your product.
- Postage fees or photo processing fees for photos sent in as documentation.
- Repairs to parts or systems resulting from unauthorized modifications made to the product.
- The removal and/or re-installation of your product.
- Shipping cost, standard or expedited, for warranty/non warranty and replacement parts.

DISCLAIMER OF IMPLIED WARRANTIES; LIMITATION OF REMEDIES

Repair or replacement of defective parts is your exclusive remedy under the terms of this limited warranty. Manufacturer will not be responsible for any consequential or incidental damages arising from the breach of either this limited warranty or any applicable implied warranty, or for failure or damage resulting from acts of God, improper care and maintenance, grease fire, accident, alteration, replacement of parts by anyone other than Manufacturer, misuse, transportation, commercial use, abuse, hostile environments (inclement weather, acts of nature, animal tampering), improper installation or installation not in accordance with local codes or printed manufacturer instructions.

THIS LIMITED WARRANTY IS THE SOLE EXPRESS WARRANTY GIVEN BY THE MANUFACTURER. NO PRODUCT PERFORMANCE SPECIFICATION OR DESCRIPTION WHEREVER APPEARING IS WARRANTED BY MANUFACTURER EXCEPT TO THE EXTENT SET FORTH IN THIS LIMITED WARRANTY. ANY IMPLIED WARRANTY PROTECTION ARISING UNDER THE LAWS OF ANY STATE, INCLUDING IMPLIED WARRANTY OF MERCHANTABILITY OR FITNESS FOR A PARTICULAR PURPOSE OR USE, IS HEREBY LIMITED IN DURATION TO THE DURATION OF THIS LIMITED WARRANTY.

Neither dealers nor the retail establishment selling this product has any authority to make any additional warranties or to promise remedies in addition to or inconsistent with those stated above. Manufacturer's maximum liability, in any event, shall not exceed the documented purchase price of the product paid by the original consumer. This warranty only applies to units purchased from an authorized retailer and or re-seller.

NOTE: Some states do not allow an exclusion or limitation of incidental or consequential damages, so some of the above limitations or exclusions may not apply to you; this limited warranty gives you specific legal rights as set for herein. You may also have other rights which vary from state to state.

If you wish to obtain performance of any obligation under this limited warranty, you should write to:

DURO CORPORATION

17018 Evergreen Place

City of Industry, CA 91745

USA

All consumer returns, parts orders, general questions, and troubleshooting assistance can be acquired by calling our customer service department at 1-888-909-8818, 9:00 a.m.- 5p.m., PST, Monday-Friday. English, French, and Spanish representatives are available. Send email to: nxrcs@duro-global.com